

SOLAR / RADIO
(OPTIONAL)

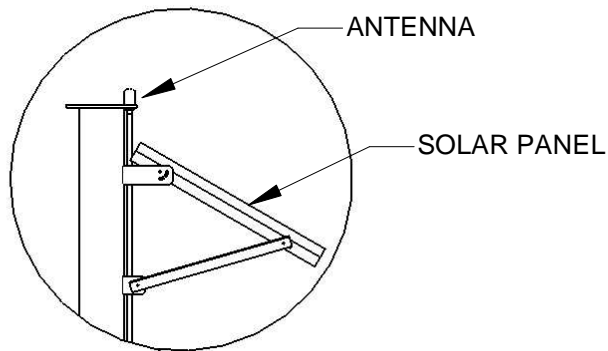

ANTENNA

SOLAR PANEL

ELECTRONICS ENCLOSURE
IP 67 (NEMA 6P)
498 H X 447 W X 224 D
HEAT SHIELD NOT SHOWN

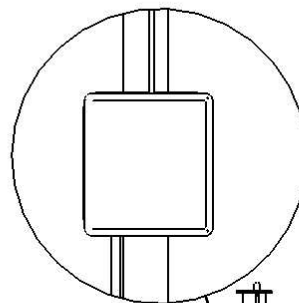

MICRO PRESSURE
SENSOR HOUSING AND
MOUNTING BRACKET

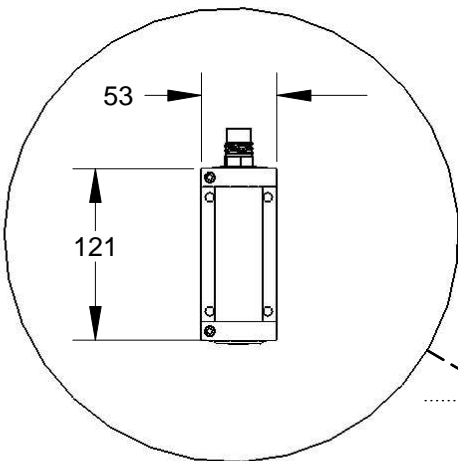

53

121

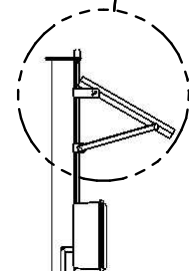

INTERFACE
CABLE &
CONDUIT

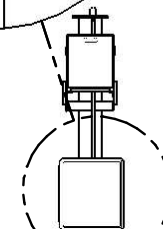
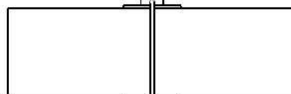

WATER LINE

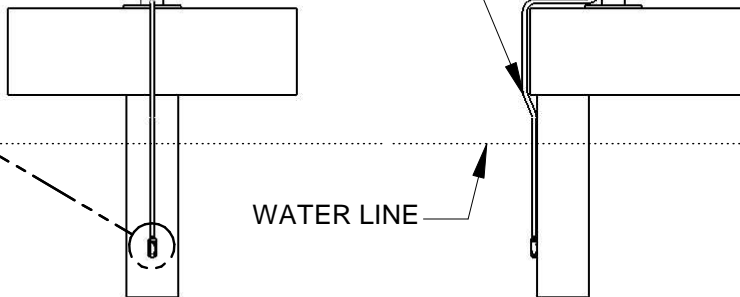

APPLIED Because it's not just 
MICROSYSTEMS

2071 MALAVIEW AVE. W., SIDNEY, B.C. CANADA V8L 5X6

TEL: (250) 656 0771 FAX: (250) 655 3655

www.appliedmicrosystems.com

TITLE
TWG PIER MOUNT CONCEPT

SYSTEM
twg

AML PART NO.
UNSPECIFIED

DATE
15-JAN-04

SLDWR NO.
W-02311-GAA