



Guillotine Pipe Saw

MODEL C, SUPER C, MODEL D AND SUPER D

Fast accurate cuts under partically all conditions

FOUR MODELS TO CHOOSE FROM...

Wachs portable Guillotine Family, cold cut 2" through 24" (50.8 mm - 610 mm) pipe of all materials, as well as solids, such as bar stock and rails. Their compact design and ease of setup provides fast, accurate cutting of pipe for contractors, water departments, gas companies and refineries, petrochemical and processing plants as well as piping applications in the nuclear industry.

EASY SETUP, VERTICAL OR HORIZONTAL ...

Installation time is approximately 5 minutes! A chain pipe vise clamps the Guillotine Saw to the pipe. The machined cast iron "V"-saddle base assures square cuts at right angles, It can be mounted on horizontal as well as vertical piping, in any position.

QUICK COLD CUTS, MINIMAL CLEARANCE...

The Guillotine Saws require minimal clearance (the model Super C needs as little as 2-1/2" on one side of the pipe). All models feature finger tip feed control. The pipe is cold cut in a matter of minutes. A 6" standard wall steel pipe is cut in only 6 minutes. A 16" dia. 1/2" wall steel pipe is cut in about 20 minutes.

PORTABLE, RUGGED DESIGN...

The Guillotine Saws combine compact size and lightweight with simple rugged construction for ease of operation and low maintenance.

LONG BLADE LIFE...

The high-speed steel blades are easily changed and since the unique Guillotine cutting action lifts the blade from the cut on the return stroke, blade life is extended.



All Guillotines can be easily modified for special cutting and mounting applications



All Guillotines are available with remote operation capability.



The "Super C" Guillotine lightweight, easy setup, rugged construction make it a perfect contractors utility saw

GUILLOTINE SAWS: MODEL C, SUPER C, MODEL D AND SUPER D

SPECIFICATIONS

CAPACITY:	Cold cuts all pipe material. Model C: 2"-8" (50 - 203 mm) pipe Solids thru 9-5/8" (244 mm) dia. Super C: 2"-12" (50 - 304 mm) pipe Solids thru 12-3/4" (323 mm) dia. Model D: 6"-18" (152 - 457 mm) pipe Solids thru 18-5/8" (473mm) dia. Super D: 10"-24" (255 - 610 mm) pipe Solids thru 24-1/2" (622 mm)
DRIVE:	Air, Electric or Hydraulic Air Motor: 50 c.f.m. @ 85 psi. / 1.4 c.u.m. @ 6 Bar Electric: 15 AMP, 110 or 220 volt single phase. Hydraulic: 10 gpm @ 1500 psi / 38 IS @ 106 Bar
CLEARANCE:	Model C: 25" (635 mm) overall width 2-1/2" (63.5 mm) on one side minimum Super C: 28" (711mm) overall width 2-1/2" (63.5 mm) on one side minimum Model D: 32" (813 mm) overall width 3" (76 mm) on one side minimum Super D: 39" (990.6 mm) overall width 3" (990.6 mm) on one side minimum
INSTALLATION TIME:	Approximately 5 minutes.
WEIGHT:	Model C: Operating: 115 lbs. (51.75 kg.) Shipping: 180 lbs. (81 kg.) Super C: Operating: 115 lbs. (51.75 kg.) Shipping: 180 lbs. (81 kg.) Model D: Operating: 340 lbs. (153 kg.) Shipping: 415 lbs. (186.75 kg.) Super D: Operating: 515 lbs. (232 kg.) Shipping: 620 lbs. (279 kg.)
DIMENSIONS:	A: Model C: 22-1/4" (565.15 mm) Super C: 23-1/2" (596.9 mm) Model D: 31-1/4" (793.7 mm) Super D: 38-1/4" (971.55 mm) B: Model C: 12" (304.8 mm) Super C: 12-3/4" (323. 85 mm) Model D: 14-1/2" (386 mm) Super D: 14-1/2" (368 mm) C: Model C: 27" (685.8 mm) Super C: 31-1/2" (800.1 mm) Model D: 37" (939.8 mm) Super D: 44" (1117.6 mm) D: Model C: 9 - 7/8" (250.83 mm) Super C: 13 - 1/4" (336.55 mm) Model D: 18 - 3/4" (476.25 mm) Super D: 24 - 3/4" (628.65 mm)
STROKE:	Model C: 2" (50.8 mm) Super C: 2" (50.8 mm) Model D: 2" (50.8 mm) Super D: 4" (101.6 mm)
CONTROLS:	Single crank, manual feed. Motor on-off.
LUBRICATION:	Grease fittings at all wear points.
FINISH:	Paint.



Model C, Model D and Super D Guillotines shown for size comparison.

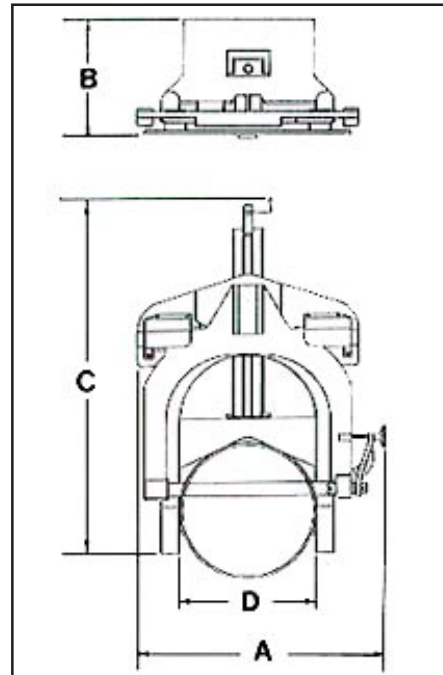

STANDARD EQUIPMENT:

- 1 blade • 1-1/4" wrench • Air Lubricator and filter (Air Model) • Steel storage case (Model C & D only) • Lifting eyes (Model D) • Mounting chains

OPTIONS:

- Model D transporter truck • Blades: general purpose, carbide (Model C only), and heavy duty blades

