

Super ZipJet

Combined excavation and jetting system

Features

- Improved performance
- Much improved ROV mounting system
- Modular pump core, readily removable for easier in-field maintenance
- Suction and jetting aligned for ease of hose management
- Optional integrated suction and jetting nozzle
- Multiple mounting and handling configurations
- Optional feedwater filter eliminates inlet hosing
- The integrated eductor based excavation system is designed to pump mud, sand, gravel, drill cuttings, shale etc. without damage to the system and with a very low risk of blockage

Applications

- The Super ZipJet is so compact that it may be mounted on most work class ROVs without the need for an additional dredging skid
- Break up of heavy and cohesive sea-bed muds and sand prior to excavation
- Removal of drill cuttings
- Deburial of subsea templates and manifolds
- Removal of marine growth prior to inspection
- Marine archaeology
- Salvage operations



The all-new Super ZipJet replaces the successful Tritech ZipJet Ultra range of products.

The Super ZipJet incorporates many technical advances over the previous generation of ROV suction and jetting systems. These advances are a direct result of customer feedback.

Considerable emphasis has been placed on increasing efficiency in both the suction and jetting modes. The Super ZipJet incorporates several design features which improve its reliability and substantially reduce its maintenance costs.

The Super ZipJet will not block or jam because there are no moving parts on the dredging side of the system. Power is derived from a stream of high velocity fluid creating a low pressure region behind the suction nozzle. The pump may be rapidly switched from suction to jetting mode.

Specifications

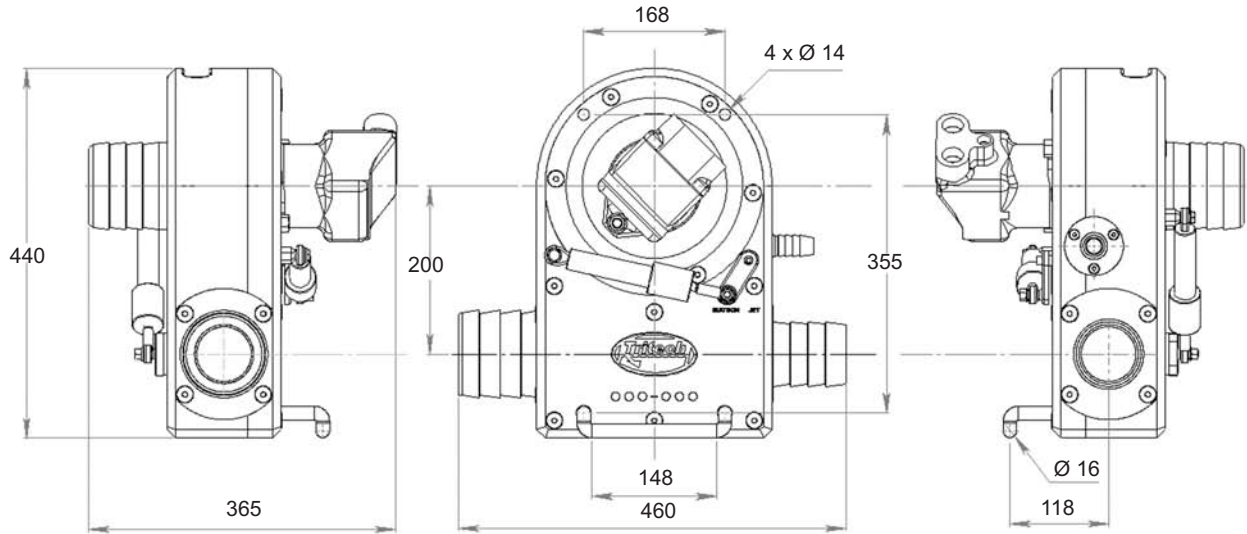

Hydraulic Input

Pressure	150 to 220 Bar	2200 to 3200 psi
Flow	45 to 60 litres / min	12 to 16 USgpm
Jetting Performance (Typical)	1000 litres / min @ 2 Bar	(264 USgpm)
Suction Performance (Typical)		
Suction Flow	500 - 1000 litres / min	(132 - 264 USgpm)
Solids Removal Rate	5 - 10 tonnes / hour	(184 - 368 lb/min)
Nozzle and Hose Dimensions		
Jetting Hose	1" BSP Hose barb	
Jet Nozzle Diameter	20 mm	0.8 inches
Discharge Hose Diameter	100 mm	4 inches
Suction Hose Diameter	75 mm	3 inches
Weights and Materials		
Weight in Air	25 kg	55 lb
Weight in Water	11 kg	24 lb
Materials	Nylacast, UHMWPE	

Larger capacity pumps can be built to order and the system may be powered electrically if required