



# SeaSoar Mk II

## Undulating Towed Oceanographic Vehicle

SeaSoar remains the first choice of leading oceanographic institutes who wish to make deep-water measurements because it has a large payload capacity and is capable of being towed at speeds from 9 to 12 knots, and undulation regimes from the surface to 500m on faired cable.



### INTRODUCTION

#### General

The SeaSoar oceanographic vehicle is a large volume instrument carrier which can be towed from a surface ship at controllable depths. It is built by Chelsea Technologies Group, under license from the Natural Environment Research Council (Southampton Oceanography Centre), UK. It is capable of carrying a large suite of sensors, at speeds of up to 12 knots to depths of 500m, following a controlled and adjustable undulating path through the sea.

SeaSoar forms part of a dynamic system where the actual depth and path pattern, obtained in practice, is dependant upon many factors. i.e. Instrumentation load, ship speed, cable tension and required YO-YO parameters. Any new system should undergo sea trials and the performance logged, to determine the optimum controller settings needed to meet the required performance.

Sampled data, obtained from sensors mounted in SeaSoar, are transmitted to the towing vessel for processing, display and storage via a multicore tow cable. A typical configuration is shown in Figure 1. The basic system comprises:

**The SeaSoar Underwater Vehicle:** This may be supplied with an unmounted pressure (depth) sensor.

**The SeaSoar Deck Control Unit:** The ship board Deck Unit is used to control the pitch of the wings thus enabling the vehicle to dive or climb as required. Operator control is via the PC based SeaFlight Software package.

Power supply to the package can be either 110V or 220V AC, 50 or 60Hz, this must be specified by the customer at time of order. Mains supply to the Deck Units must provide an EARTH terminal.

**Training:** Chelsea Technologies Group will also supply two days of 'at sea' training. Experience has shown that this is very cost effective when taking into account the avoidance of set-backs, delays and possible damage.

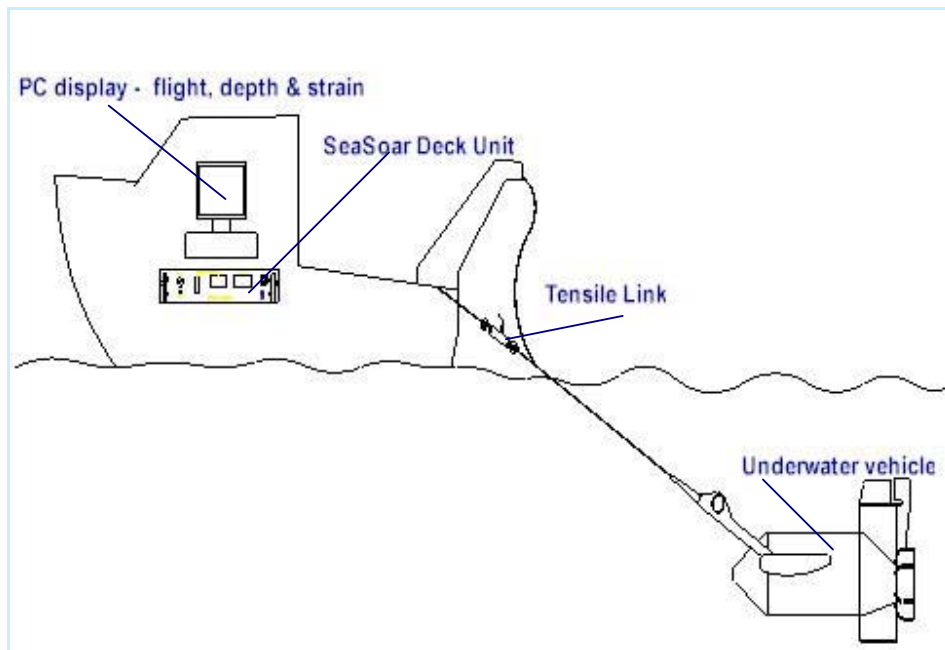

**Figure 1 – Standard Configuration**

## Options

The SeaSoar system has been designed as a very flexible package. The Standard Package can be purchased as a basic towing unit or together with a range of options.

CI Ltd. can supply an extensive range of underwater monitoring instruments, including sensors for CTD, pH, Redox, Dissolved Oxygen, Turbidity, Transmission and Fluorescence.

Specific options relating to the SeaSoar System that can be supplied include:

- A suitable winch, cable, cable fairing and associated equipment to suit the varying applications of the SeaSoar System.
- The design and production of a suitable underwater cable harness for connection of the SeaSoar hydraulic unit and any sensors carried, to the tow cable.
- The design and supply of suitable mounting arrangements for varying instrumentation payloads, together with a single or double push-rod assembly for the hydraulic unit to allow a wider variety of mounting arrangements within the vehicle.

- Deck Transportation Cradle - A welded steel deck cradle, painted for use in a marine environment, is provided for stowage of the SeaSoar vehicle when on the deck of the operating vessel. This cradle additionally aids transportation of the SeaSoar system between laboratory and ship or into storage. The cradle comes supplied with casters for ease of mobility and is also supplied with brackets which can be welded to the deck of the operating vessel to secure the cradle for stowage at sea.
- Tensile link (either separate or integral to the winch system) to give a real time readout of cable tension.
- Engineering package for SeaSoar to give a real time display of vehicle pitch, roll and yaw.
- Basic operational spares kit for the Vehicle, Hydraulic Unit and a SeaSoar tool kit.
- A Servo Valve / Wing Movement Test Box and interface cable is available allowing a test signal (current) to be sent to the electro-hydraulic servo valve (Moog) within the SeaSoar hydraulic unit, and thus initiating wing movement when the impeller is turned by hand.

### **Principle of Operation**

The SeaSoar is an undulating towed vehicle capable of deploying a large oceanographic payload to depths of up to 500m, depending upon tow cable configuration. Power is supplied to the wing actuating ram by a water driven impeller connected to the hydraulic pump within the SeaSoar hydraulic unit. The system utilises a digital servo loop in which the wing angle of the vehicle is controlled by the difference between the observed pressure and a synthesised command signal. Based on this difference, the SeaSoar deck unit generates a current signal that proportionally controls a servo valve within the hydraulic unit to either extend or retract the hydraulic ram. The ram is coupled to the wings rotating them through varying pitch angles to enable SeaSoar to climb or dive through the water column.

It is recommended that SeaSoar be towed on Rochester 7-H-314 AXX 8.2mm diameter, double armoured, 7 conductor cable or a close equivalent. With an unfaired tow cable SeaSoar will reach depths from 0 – 100 metres. With low drag Indal fairing fitted to the outboard end of the tow cable much greater depths can be achieved. A 650m cable with the outboard 500m faired gives SeaSoar a maximum depth capability of 350 - 400m, whilst a 1000m tow cable with the outboard 750m faired enables SeaSoar to reach the desired depths of 450 - 500m.

## SPECIFICATION

### *SeaSoar Body*

Length	2m
Height (rudder bar down)	0.98m
Width over wing hooks	1.60m
Weight, in air (inc. hydraulic unit excluding Sensors)	150kg

### *Recommended Tow Cable*

Type	Rochester 7-H-314AXX (High strength armour)
Diameter	8.2mm
Conductors	7
Breaking strain	51.6 kN
Working load	20.0 kN
Bend diameter (min.)	43 cm
Weight:	
Air	268 kg/km
Freshwater	220 kg/km

### *Recommended Fairing*

Type	Indal Technologies Flexnose FA-478-350-1
Section length	10.2 cm
Sheave diameter	91 cm (minimum)

### *Typical Performance*

With cable (1000m)	Flexnose fairing	Unfaired
Maximum depth	500m	100m
Maximum tow speed	12 knots	12 knots
Minimum operating speed	9 knots	9 knots
Maximum rate of change of depth	1m/sec	4.5m/sec
Level towing accuracy	+/- 3m	+/- 1m

### *Typical Winch*

With cable	*Faired	Unfaired
Drum diameter (minimum)	1.75m*	0.45m
Drum capacity	750-1000m*	250m
Maximum pull	400kg	300kg
Maximum line speed	1m/sec	1m/sec
Minimum line speed	5m/min	5m/min

\* Dependent upon the type of fairing and cable length employed.

## **VEHICLE CONSTRUCTION**

The Underwater Vehicle, illustrated in Figure 2, consists of the following main sections:

### **Towing Bridle**

The bridle applies the tow cable forces to the wing drive shaft. Being made from stainless steel, it is a very stiff structure, designed to cope with the weight of the vehicle body and hard driving of the system.

### **Two Wings with Hook Rails**

The wings are moulded from glass reinforced polyester, they are very strong with 50mm dia. stainless steel pivots which are connected together by a drive shaft. The drive shaft is coupled to the hydraulic ram via a short crank which converts ram motion to wing rotation. Both single and double push rod options are available, unless specified by the customer a single push rod is supplied as standard. Hook Rails assist in the recovery procedure.

### **Main Body**

The central body is rectangular with a stainless steel, deep-sided frame, this provides maximum volume for instrument carrying and strength. Quick release stainless steel panels, top and bottom, allow maximum accessibility without the use of tools. The central section is bolted to streamlined GRP nose and tail sections. The use of stainless steel and GRP minimises corrosion and enhances the durability of SeaSoar.

The stability of the vehicle is enhanced by hanging a streamlined weight below the front of the body. This, together with the streamlined nose and high profile tail section, adds to the towing stability of the vehicle. The streamlined weight may not be required when large instrument loads are carried.

## **Tail**

The tail surfaces consist of two flat, horizontal reinforced polypropylene plates mounted on and connected to, the main body by a similar vertically positioned plate. One horizontal plate is located well above the top of the vehicle body, the other well below.

### **Rudder Plate and Balance**

A stainless-steel rudder plate and balance arm is fitted to the rear of the tail section as a stabiliser. It is freely hinged to the tail by means of pintles. When the vehicle rolls to one side, the effect of gravity on the balance arm turns the rudder in the same direction. The resulting hydrodynamic force acts to return the vehicle to vertical as well as correcting yaw.

### **Impellor with Ring Guard**

The Impellor is mounted at the rear of the main body beneath the rudder. It is used to drive a hydraulic gear pump which generates power for the hydraulic ram which, in turn, pivots the wings. Constructed from stainless steel, the impellor has six blades and is 280mm in diameter. A guard ring is fitted to protect the impellor from damage during operation and deployment.

### **Hydraulic Unit (Mark II)**

A new Mark II hydraulic unit has been developed to meet the need of prolonged deployments at sea with minimal maintenance requirements. After an extensive programme of laboratory and at-sea trials this is now fitted as standard to all SeaSoars.

The Hydraulic Unit is located within the Main Body of SeaSoar. As the vehicle is pulled through the water, the impellor drives an axial piston pump which generates hydraulic pressure. This pressure is fed to the servo valve which controls the flow of oil to the double acting piston in response to a control signal supplied from the SeaSoar Controller via the tow cable. Movement of the piston alters the angle of the wings by means of a push rod arrangement acting on the wing crankshaft.

**Note: Single or Double Push Rod options are available; this must be specified at time of order.**

The unit does not incorporate an internally mounted pressure transducer; depth feed-back for vehicle control from the surface is supplied by either the existing CIL pressure transducer mounted in a separate pressure housing assembly, or depth sensors available on auxiliary 'payload' instrumentation.

The unit incorporates supply and return line filters to maintain the correct ISO oil cleanliness code during operation, includes an adjustable pressure relief-valve to set the maximum wing-shaft 'stalling' torque.

To ensure that the actuating force is the same in each direction of travel and to maintain a fixed volume servo-circuit, the double-acting piston is pressure balanced via an additional internal sea water port. Minor variations in volume with piston travel and the larger volume changes as a result of the coefficient of thermal expansion of the oil over the storage temperature range of the unit, are allowed for by using an internally mounted compensator piston.

The new Mark II hydraulic unit is electrically compatible with the existing Mark I unit. It is readily installed into existing SeaSoars using an adaptor kit and will not intrude into any additional internal payload areas. The centre of gravity of the SeaSoar is not significantly affected.

Each new Mark II hydraulic unit is issued with a performance certificate showing the input and output powers achieved.

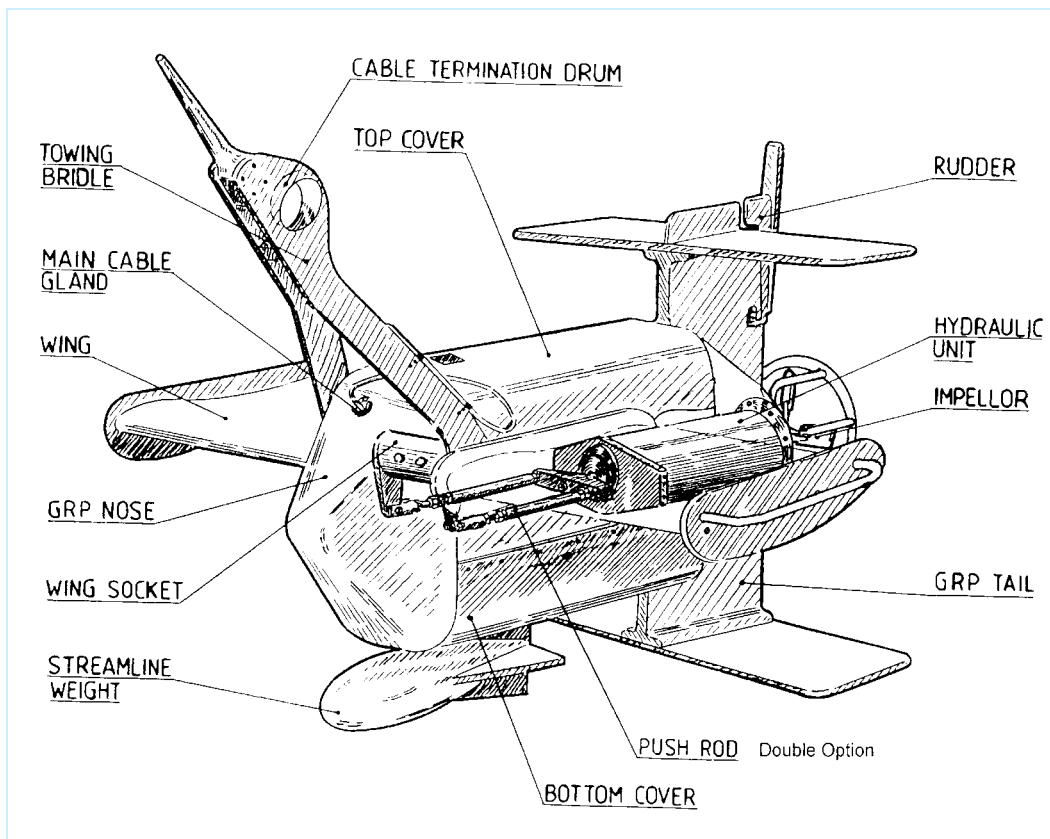

Figure 2 - The Underwater Vehicle

## DECK UNITS

The original SeaSoar Deck Controller has now been replaced by a PC based system. This enables the user to have real time computer control over the SeaSoar's flight profile together with the storage and display of the flight parameters.

The SeaSoar Controller consists of a small deck unit, which under PC control, generates the error current which is passed down the tow cable to the electro-hydraulic servo valve within the SeaSoar hydraulic power unit. This valve error current controls the extension or retraction of the hydraulic ram which in turn sets the SeaSoar wings into the dive or climb attitude. See Figure 3 below:

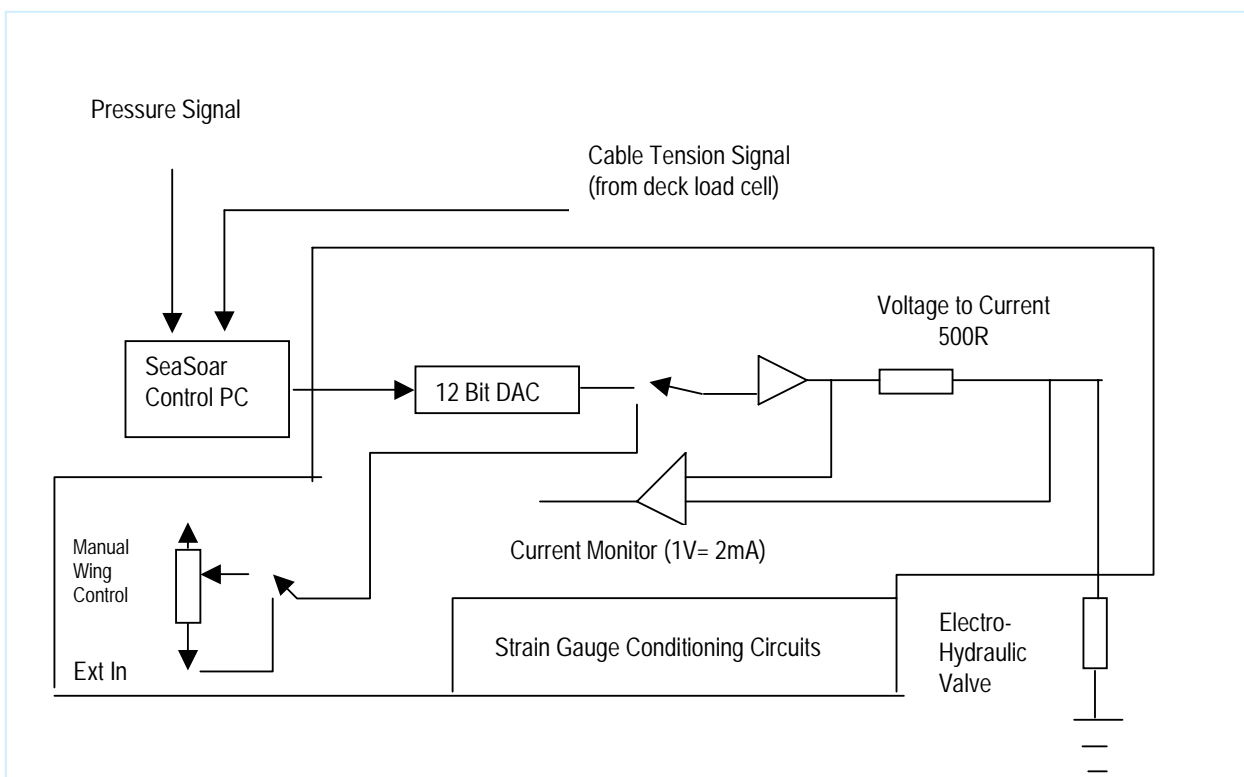

Figure 3

### Minimum Computer Specification:

- 100 MHz Pentium processor (or equivalent)
- 8 Mbyte RAM
- 3.5" floppy disc drive
- 500 Mbyte hard disc
- 14" colour SVGA monitor
- DOS 6.22

The SeaFlight BASIC programme, running on the SeaSoar Control PC generates a saw-tooth command pattern which represents an ideal trajectory for the SeaSoar. The shape and DC level of the command curve is set via software. The difference between the command signal and pressure measured inside the SeaSoar vehicle (taken either from an installed CTD system, or a separate pressure transducer) is the loop following error signal. This error signal is passed to the SeaSoar Deck Unit, via the PC printer port, where it is converted into the corresponding current signal. This current, called the valve current, is sent down the tow cable to set the electro-hydraulic valve in the hydraulic unit to either extend or retract the hydraulic unit's piston. The hydraulic piston in turn moves the SeaSoar wings into wing-up or wing-down positions at a rate proportional to the valve current. A feedback loop is thus formed, in which the pitch of the SeaSoar wings is continually adjusted as the vehicle attempts to alter its depth until the output of the pressure transducer matches the command signal.

AN ADC card fitted to the SeaSoar Control PC enables the signal from the tow cable load cell (if fitted) to display and log the cable tension.

The SeaSoar deck unit (heavy line in Figure 3) is configured in a 19" 2U high mains powered case, with a front panel mounted analogue edge meter displaying the valve current. The meter needle provides an indication of SeaSoar's attitude with up / down orientations corresponding to SeaSoar climbing and diving respectively. The actual valve current sent down the tow cable is also displayed digitally on the front panel and monitored by the SeaSoar Control PC. The current generator design is such that the valve current passed to the SeaSoar hydraulic unit is independent of the load presented by the tow cable/electro-hydraulic valve. Additionally, a front panel switch allows the user to over-ride the SeaSoar flight programme, permitting manual control of the vehicle wing angle via a front panel potentiometer. In the event of a computer malfunction this facility allows SeaSoar to be brought to the surface and recovered in a controlled manner.

## SOFTWARE

### SeaSoar Flight Control Software "SeaFlight"

The SeaFlight control software enables the user to programme SeaSoar's undulation profile and the system servo parameters. The software provides for user control of the following parameters.

- |               |   |   |
|---------------|---|---|
| 1. $P_{min}$  | - | minimum depth                               |
| 2. $P_{max}$  | - | maximum depth                               |
| 3. Period     | - | period of undulation                        |
| 4. $g_0$      | - | 1st programmable gain                       |
| 5. $g_1$      | - | 2nd programmable gain                       |
| 6. $P_{up}$   | - | Wing will not turn "up" before $P_{up}$     |
| 7. $P_{down}$ | - | Wing will not turn "down" before $P_{down}$ |
| 8. Bias       | - | Bias to valve current                       |

Visually SeaFlight displays the following parameters and logs them to the PC hard disk should future analysis be necessary.

1. Command Voltage
2. Pressure (CTD)
3. Error Current (to electro-hydraulic valve)
4. Cable Tension (at the deck)

The PC page up / page down keys give the user direct control over SeaSoar's wing angle, overriding the computer flight programme, permitting manual adjustment of the vehicles climb or dive through the water column. Thus, in an emergency (say in shallow waters) the user can rapidly command SeaSoar to climb to the surface at a keystroke (page up). Additional manual intervention allows the user to advance or retard the command voltage bringing the command signal and SeaSoar's actual flight profile back into phase should they start to diverge. After manual intervention SeaSoar can be put back under computer control via the keyboard.

## WINCH AND CABLE SYSTEM

SeaSoar requires a dedicated winch and cable system, this may be a fixed installation or a mobile system. The user's individual requirements dictate the type of winch used. The operational depth will dictate whether the tow cable is faired or un-faired; this will influence the type of winch required, using un-faired, a multilayer drum will suffice. The use of fairing necessitates a single layer winch and hence a larger winch barrel.

**Note: The winch is only used to deploy and recover SeaSoar; during towing the cable MUST be stopped to a firm fixing point on the ship structure.**



Typical Winch

Chelsea Technologies Group do not manufacture oceanographic winches. We have built a strong liaison with several approved suppliers who can provide electric, hydraulic and diesel hydraulic winches specifically designed for use with SeaSoar.

### Typical Winch (Unfaired Cable)

Designed to handle up to 250m of un-faired cable, typically powered by a 5kW electro hydraulic drive and has single lever bi-directional speed control. Line speeds are variable between zero and 1 m/sec with a max. line pull of 300kg. Reeving gear allows the cable to be spooled neatly onto the drum. A slip-ring unit allows continuous control of SeaSoar while launching or recovering. A small hydraulically held off, disc brake will hold the cable at up to 300kg loads but is not designed to sustain full towing loads. A plain cable of typically 250m in length will allow a maximum depth of about 100m to be attained. Longer cable lengths are possible but it is necessary to determine this during sea trials, where vehicle performance and cable strain are closely monitored.

## **Typical Winch (Faired Cable)**

To attain the full performance of SeaSoar it is recommended that 1000 metres of Rochester cable (7-H-314AXX) is used, of which 750 metres is faired using the Indal Technologies FA-478-350-1 Flexnose Fairing. At a speed of 10 knots, an undulation range from the surface to 500 metres may be achieved.

This configuration will require a dedicated winch and towing sheave system. The faired tow cable can only be reeled onto a single layer winch drum to avoid damage to the fairing. The final pulley sheave (suspended from the towing vessels' A-Frame) must be of sufficient bend diameter (91 cm minimum) but also have an appropriate lead in device to orientate the free-hanging fairing.

## **Lifting Equipment**

In order to launch and recover the vehicle, it is necessary to have a means of lifting it over the stern, preferably an 'A' frame. The tow cable is led over the launching sheave attached to the 'A' frame in such a manner that the cable may be transferred to the towing sheave on completion of the launch. The 'A' frame should extend at least as far behind the vessel as the deck is above the water level. If an 'A' frame is not available an articulated crane may be used. This can cause complication in the launch and recovery processes, as the SeaSoar winch and crane operators have to work in unison. The crane should have a lifting capacity of not less than 400kg at a reach well clear of the ships stern. The wing hook rails can be used to steady the vehicle during launch and recovery.

## **Tow Cable Strain Gauge**

A five tonne strain gauge (Straininstall load cell type 1849) is available for fitting to the deck end of the tow cable, enabling the SeaSoar towing loads to be monitored during deployment. The strain gauge is powered via a four core screened deck cable running from the SeaSoar Deck Unit to the winch. A 50m strain gauge deck cable is provided, through which the strain gauge output is also routed back to its conditioning amplifier in the SeaSoar Deck Unit. The cable tension is displayed and logged with the other SeaSoar flight parameters on the SeaSoar Control PC.

Once SeaSoar is deployed the strain gauge is attached to the tow cable and anchored to a deck strong point, this arrangement additionally serving to remove the towing loads (up to 1400 Kg) from the winch during extended tows. Load transfer is achieved by taking the towing strains through the strop arrangement (Figure 4).

The load transfer arrangement requires the supply of the following items, all of which will be supplied proof tested to 3 tonne.

- Strop 1 Deck strong point to strain link strop constructed from 11mm galvanised wire 2 metres long, terminated each end with a thimble.
- Strop 2 Strain link to cable puller strop constructed from 11mm galvanised wire 3m long, with a thimble each end and a swivel in the middle.
- Cable Puller\* For transferring the towing loads from an unfaired section of the 7-H-314AXX tow cable to the strop arrangement.
- 4 off shackle For terminating the loose ends of the two strops.

Several winch manufacturers incorporate the strain gauge within the winch drum. This offers a very simple solution and negates the need for separate strops and cable pullers. This may be specified as part of the overall SeaSoar system.

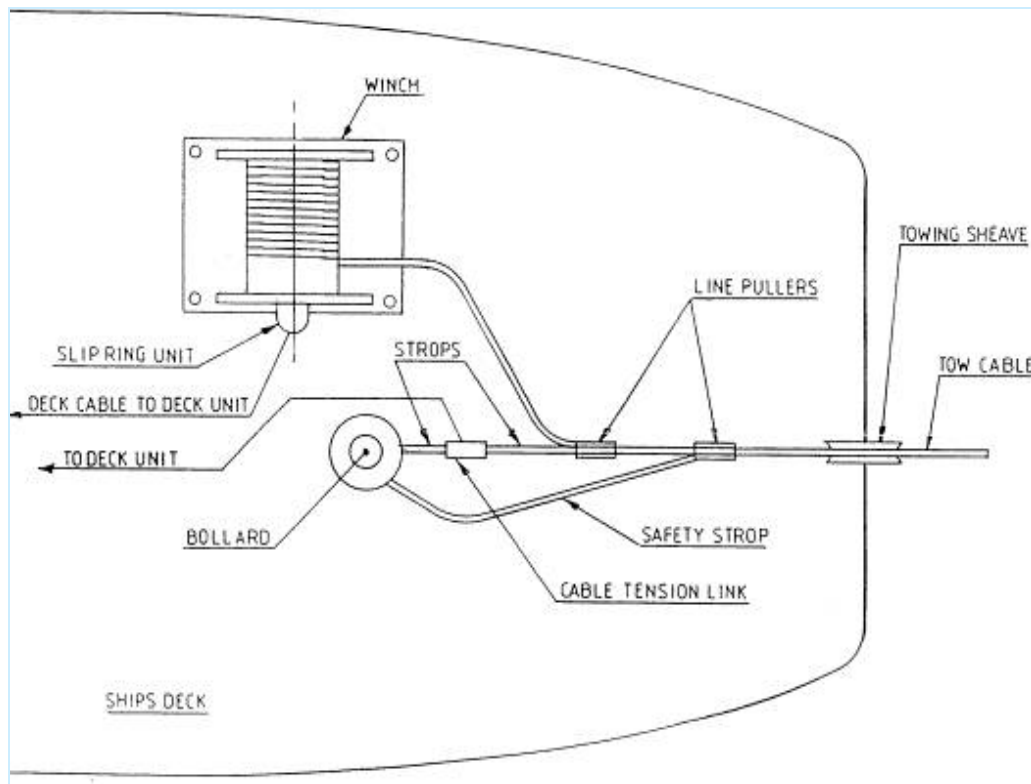

Figure 4 – Towing Arrangement

## SeaSoar Underwater Body Deck and Transportation Cradle

A welded steel deck cradle, painted for use in a marine environment, is provided for stowage of the SeaSoar vehicle when on the deck of the operating vessel. This cradle additionally aids transportation of the SeaSoar system between laboratory and ship or into storage. The cradle comes supplied with casters for ease of mobility and is also supplied with brackets, which can be welded to the deck of the operating vessel to secure the cradle for stowage at sea.



### CHELSEA TECHNOLOGIES GROUP HAS A VEHICLE TO MEET YOUR NEEDS

The full range of Chelsea's towed undulating vehicles (from large carriers capable of undulating down to 500 metres, to vehicles designed for deployment from smaller towing vessels and ships of opportunity) include SeaSoar MkII, AQUA*shuttle* and Nv-Shuttle.

We have a vehicle to meet your needs,  
so please contact us to discuss your  
particular requirements.

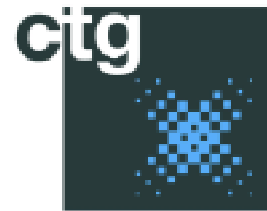

**Chelsea  
Technologies  
Group**  
55 Central Avenue  
West Molesey  
Surrey KT8 2QZ  
United Kingdom  
Tel: +44 (0)20 8481 9000  
Fax: +44 (0)20 8941 9319  
sales@chelsea.co.uk  
www.chelsea.co.uk

December 04