

PolaNt*: GPS and GPS/GLONASS antenna.

PolaNt is a lightweight high precision geodetic antenna family for geodetic and survey applications. This high-gain antenna incorporates low-noise amplifiers, enables single or dual frequency GPS & GLONASS signal reception and is built into a rugged and environmentally sealed housing.*



PERFORMANCE

	PolaNt*	PolaNt*_GG	PolaNt*_SF
Frequency	1575 ±10 MHz 1227 ±10 MHz	1590 ±25 MHz 1238 ±21.5 MHz	1575 ±2 MHz
Polarization	RHCP	RHCP	RHCP
Axial Ratio	3dB max	3dB max	3dB max
Radiation Coverage			
θ = 0°	4.0 dBic	4.0 dBic	4.0 dBic
0° < θ < 75°	-1.0 dBic	-1.0 dBic	-1.0 dBic
75° ≤ θ < 80°	-2.5 dBic	-2.5 dBic	-2.5 dBic
80° ≤ θ < 85°	-4.5 dBic	-4.5 dBic	-4.5 dBic
θ = 90°	-7.5 dBic	-7.5 dBic	-7.5 dBic
Amplifier			
Gain	38 ± 2 dB	26 ± 2 dB	26 ± 2 dB
Noise Figure	2.6 dB max	2.6 dB max	2.5 dB max
Input Voltage	+3 to +18 VDC	+3 to +15 VDC	+3 to +15 VDC
Current	55 mA (typ)	45 mA (typ)	30 mA (typ)
Impedance	50 Ω	50 Ω	50 Ω
VSWR	≤ 2.0:1	≤ 2.0:1	≤ 2.0:1
Band Rejection	35 dB @ 1625 MHz	35 dB @ 1675 MHz	35 dB @ 1625 MHz

PHYSICAL AND ENVIRONMENTAL

	Weatherable polymer	Weatherable polymer	Weatherable polymer
Finish	Weatherable polymer	Weatherable polymer	Weatherable polymer
Weight	≈ 386 gr	≈ 386 gr	≈ 312 gr
Diameter	160 mm	160 mm	160 mm
Connector	TNCF	TNCF	TNCF
Altitude	≤ 6000m (20000ft)	≤ 3600m (12000ft)	≤ 3600m (12000ft)
Temperature	-40°C to +75°C	-40°C to +75°C	-40°C to +75°C

OTHER SEPTENTRIO PRODUCTS

PolaRx2eH and PolaRx2e@ - A unique single-board dual-frequency multi-antenna receiver that can be connected to 2, respectively 3 antennas, for various machine control, heading/attitude and other multi-antenna applications.

AsteRx1 - Compact single-frequency GNSS receiver platform, offering top-quality GPS and Galileo code and carrier phase data and single frequency positioning (including GPS DGPS and L1-RTK) at up to 50 Hz.

AsteRx2 - Compact dual-frequency GPS/GLONASS receiver platform, offering top-quality GPS code and carrier phase data and dual-frequency positioning (including DGPS and L1/L2-RTK) at up to 20 Hz.

PolaRx3 - A versatile high-accuracy dualfrequency GNSS receivers for precise positioning and navigation applications. Next to high-quality GPS measurements, it provides GLONASS dual-frequency data as well as modernized GPS (L2C).

PolaRx3G - A high-performance integrated dual-frequency GNSS receiver that provides access to the new and upcoming Galileo signals. The modernized GPS signals are also supported.

PolaRx3TR - A high-performance integrated dual-frequency GNSS Timing/Reference receiver.

RxControl - RxControl is an intuitive user interface to configure and control all types of PolaRx receivers and monitor, log and post data remotely.

RxMobile - A unique intuitive, portable GUI field controller for the Septentrio receivers. RxMobile allows controlling the receiver, monitoring the navigation solution and accessing its functions in the field in the same intuitive way as with RxControl.

DIMENSIONS

Dimensions in inches

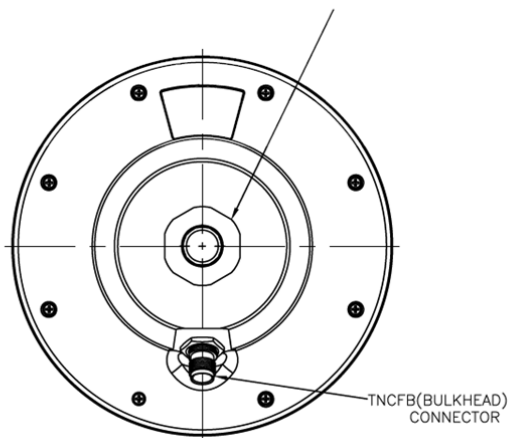
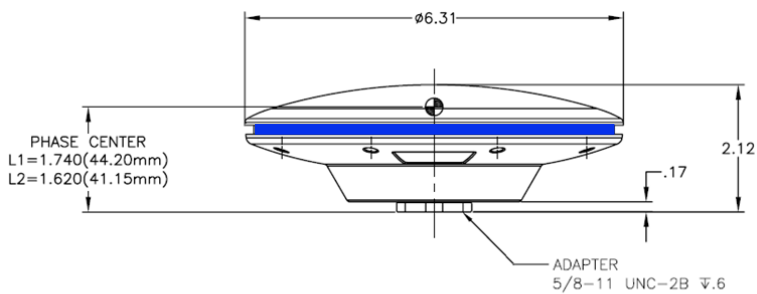
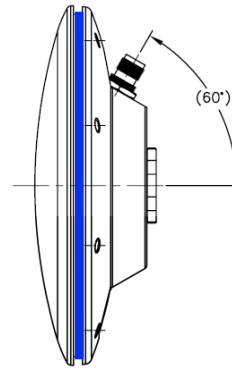
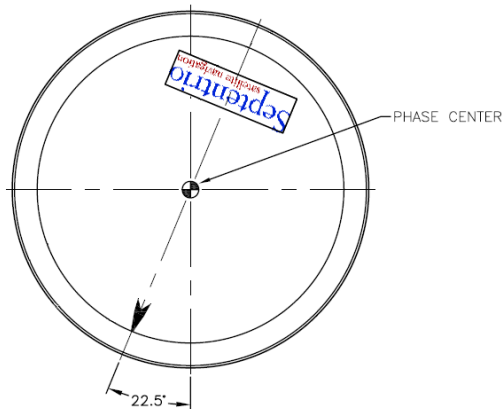

Remark :

- Blue = Dual Frequency GPS
- Black = Dual Frequency GPS GLONASS
- Red = Single Frequency GPS

SSNDS 09/2008/1

Headquarters :
Ubicenter, Philipssite 5
B-3001 Leuven
Belgium

Phone: +32 16 300 800
Fax: +32 16 221 640
info@septentrio.com
www.septentrio.com

Although believed to be accurate and reliable, Septentrio reserves the right to alter the above specifications without prior notice. However, no responsibility is assumed by Septentrio for its use, nor for any infringements of patents or other rights of third parties resulting from its use.