

# Aquadopp®

## Open water 3D Current Meter

Imagine an ocean current meter without need for recalibration, without moving parts, with the ability to withstand fouling and with the sampling volume moved away from the mounting structure. These are among the factors making the Aquadopp® family the most versatile ocean current meters available. Leading oceanographers and engineers all over the world use the Aquadopp®. Typical applications are:

- ✓ Self-contained deployments
- ✓ Permanent monitoring stations
- ✓ Real time data collection on buoys, ROVs, off-shore platforms, etc.

The Aquadopp® is usually configured from a PC, but it can be operated from any third-party controller using the RS232/RS422 interface (binary or ASCII) or analog outputs.

### Software

The Aquadopp® comes standard with Windows® software both for real time data collection and for controlling autonomous deployments. Different views and menus guide you through the process from configuration to data conversion. The software has an extensive on-line help section and requires no special skills.

New firmware versions from Nortek can be loaded into the Aquadopp® using the standard software, removing the need for opening the canister and replacing components.

The effect of magnetic deployment frames can be eliminated in the on-line compass calibration procedure.

In the final analyses, the Aquadopp® offers great value through the combined use of advanced Doppler technology and a flexible system design.

#### Wave directional spectra

The Aquadopp® can be configured to collect wave directional data at the same time as it measures the mean current. Nortek provides postprocessing software that allows you to calculate the wave spectra from the raw data.



The Aquadopp® has several significant advantages when compared to other open water current meters:

- ✓ All plastic and titanium parts stops corrosion
- ✓ Small and light weight (less than 3kg!)
- ✓ No moving parts that can be blocked or sensitive parts that are easily damaged
- ✓ Low power consumption for long deployments
- ✓ A variety of sensor heads and the ability to move the sampling volume away from the mounting structure assure undisturbed measurements in all situations.

#### Diagnostic mode

The diagnostic mode is unique for Aquadopp®. It allows the user to intersperse the average data with periods of rapid sampling (1Hz). Diagnostic data are typically used to analyze mooring motion or to gather information about surface waves or internal waves.



# Aquadopp Head Configurations – collecting

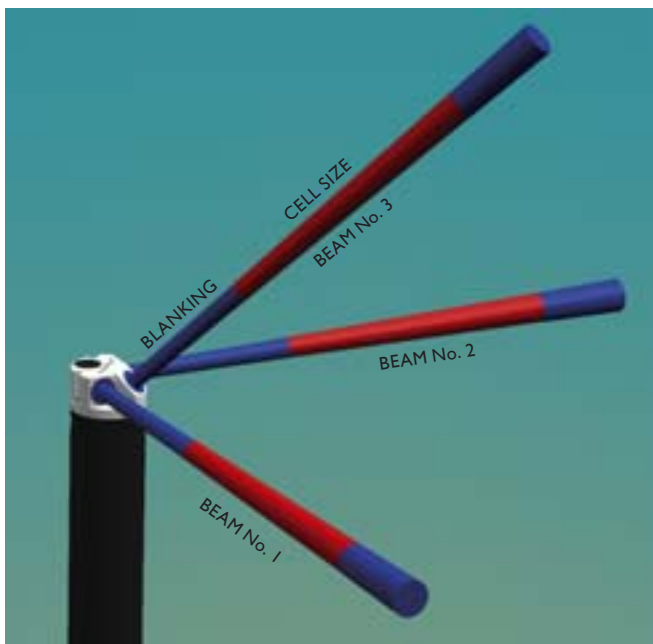

A variety of sensor heads are available for the Aquadopp®. Each head is optimized for certain applications to ensure that you can collect data which you really want to.

The Aquadopp® measures the Doppler shift occurring when transmitting and receiving sound along two or more narrow acoustic beams. The Doppler shift is proportional to the velocity component along the beam. The data can be combined, using the exact geometry, to generate 2D (minimum 2 beams) or 3D velocity (minimum 3 beams).

## Sampling Area, Blanking and Cell Size

The sampling area is determined by the blanking, cell size, and beam geometry, as shown in the above Fig. The parameters blanking and cell size are user selectable in software, whereas the geometry is determined by the orientation of the acoustic beams. The tilt and the compass sensor in the Aquadopp® work equally well whether it points up or down. Consequently, any head may be used up-looking just as well as down-looking.

## Custom Sensor Design

The Aquadopp® sensor head is made from a tough epoxy and polyurethane plastic materials suitable for molding. This allows us to design and construct new sensor heads with a lead time of four weeks or less. Contact Nortek or your local representative today if you have applications that may require a new sensor head design!

## Other Sensors

All heads have tilt and temperature sensors built in. Pressure sensor is standard for all heads except for the 2D side-looking head.

A typical application for the 2D side-looking sensor head is to measure 2D flow away from walls or boundaries. Shown here is an example of channel flow monitoring where the Aquadopp® is mounted on the channel wall, protected from floating debris, and the measurements are made in the free flow away from the wall.



A European military contractor has developed a system for mine hunting based on a powerful ROV. The ROV runs ahead of the ship at a distance of a few hundred meters, tracking targets as it goes. To measure the speed and direction, the vehicle is fitted with an Aquadopp® with right-angle sensor head to get accurate readings at 1-sec intervals.

An Aquadopp® with a symmetric sensor head can be used to measure at a fixed distance above the bottom.

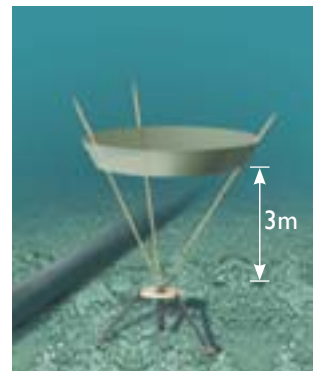

## AquaFin Deployment Fixture.

The AquaFin is designed for mooring an Aquadopp® Current Meter or a Current Profiler. It shackles into the mooring line and allows the Aquadopp® to swivel freely so that its beams always look into undisturbed flow. Choose non-magnetic stainless steel or titanium for mooring loads of 450, 900, and 1350 kg, respectively.

Dimensions are:  
414 mm × 684 mm (w × h).  
Fin alone is 306 mm wide.



# ing data undisturbed by flow interference

## Head Configurations

### Standard sensor head

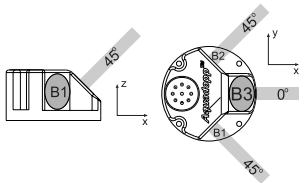

The **Standard sensor head** is designed for mooring applications. The transducer orientation is optimized to give the best possible precision for the horizontal velocity. All three transducers are mounted on one side and the instrument should be mounted to assure that the beams are pointing into the undisturbed flow. In the case of a mooring line, this can be achieved by attaching a balancing fin to the Aquadopp® or by using the Aquafin.

### Right angle sensor head

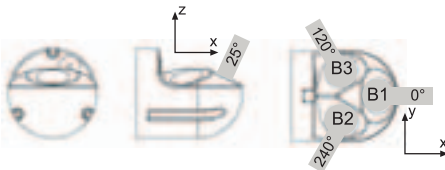

The **Right-angle sensor head** is used when it is important to give the instrument a low profile to minimize drag. Typical examples are bottom frames, ROVs, and applications where the Aquadopp® will be towed.

### Symmetric sensor head

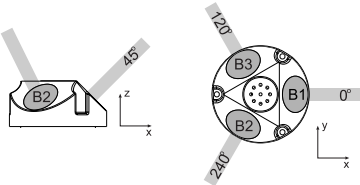

**Symmetric sensor heads** are designed to measure above or below the Aquadopp®. The most common application is Aquadopp® units mounted on bottom frames. In addition to measuring above the frame at a programmable distance, the vertical extent of the sampling volume is more precisely defined with the symmetric design than with the standard head, which is designed for mooring applications.

### Asymmetric sensor head

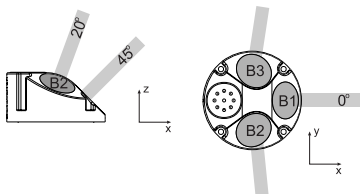

The **Asymmetric sensor head** is used in situations where the sample area is best located above (or below) the instrument and out to the side. A good example is buoy mounted Aquadopp® units, where the measurement area should be positioned both below the hull and away from the anchor chain.

### Hockey-puck-looking sensor head



The **Hockey-puck-looking sensor head** has all three beams in the horizontal plane. The sensor head can only measure 2D velocity, but has the advantage that one of the beams can be eliminated in the calculation of the horizontal velocity. This head can be used when making measurements close to the surface or bottom.

### 2D side-looking sensor head

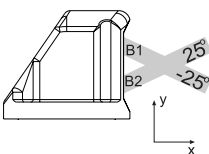

The **2D side-looking sensor head** is used to measure 2D flow away from walls or boundaries. Typical applications include channel flow monitoring where the Aquadopp® is mounted on the channel wall – protected from floating debris – and the measurements are made in the free flow away from the wall.

**Sensor head nomenclature.** The acoustic beams are defined by their unity vectors  $B_i$  in the reference coordinate system XYZ. The reference system remains constant, regardless of the sensor orientation. The conversion from beam velocity to XYZ velocity is given by the inverse matrix generated from the  $B_i$  vectors.

Should none of these configurations fit your application, note that other head configurations are available on request.

# Specifications

## Water Velocity Measurement

Range	±5 m/s (inquire for higher ranges)
Accuracy	1% of measured value ±0.5 cm/s
Maximum sampling rate (output)	1 Hz, 2 or 4 Hz on request
Internal sampling rate	23 Hz

## Measurement area

Measurement cell size	0.75 m
Measurement cell position (user selectable)	0.35–5.0 m
Default position (along beam)	0.35–1.8 m

## Doppler uncertainty (noise)

Typical uncertainty for default configurations	0.5–1.0 cm/s
Uncertainty in U,V at 1Hz sampling rate	1.5 cm/s

## Echo Intensity

Acoustic frequency	2 MHz
Resolution	0.45 dB
Dynamic range	90 dB

## Sensors

<b>Temperature</b>	Thermistor embedded in head
Range	–4°C to 40°C
Accuracy/Resolution	0.1°C/0.01°C
Time response	10min

<b>Compass</b>	Flux-gate with liquid tilt
Maximum tilt	30°
Accuracy/Resolution	2°/0.1° for tilt < 20°

<b>Tilt</b>	Liquid level
Accuracy/Resolution	0.2°/0.1° for tilt < 20°
Up or down	Automatic detect

<b>Pressure</b>	Piezoresistive
Range	0–200 m (standard)
Accuracy/Resolution	0.5% / Better than 0.005% of full scale per sample

## Analog inputs

Number of channels	2
Voltage supply	12V. Hardware can be modified to provide 5V or battery voltage.
Voltage input	16 bit A/D

## Data Communication

I/O	RS232, RS422, or analog outputs Software supports most commercially available USB–RS232 converters.
Baud rate	300–115200
User control	Handled via WIN32® software, ActiveX function calls, or direct commands with binary or ASCII data output.

## Software (“Aquadopp”)

Operating system	Windows® 2000 & XP Functions Deployment planning, start with alarm, data retrieval, ASCII conversion. Online data collection and graphical display. Test modes.
------------------	--

## Data Recording

Capacity (standard)	9 MB, expandable to 33, 89, or 161MB
Data record	40 bytes
Diagnostic record	40 bytes

## Power

DC input	9–16VDC
----------	---------

Peak current	2A at 12VDC (user adjustable)
Max. consumption, IHz	0.2–1.0 W
Avg. consumption	0.1 W (0.02 Hz), 0.01 W (0.002 Hz)
Sleep consumption	0.0013 W
Battery capacity	50 Wh. Extended 6000 m version has 2 battery packs (i.e. double capacity)
New battery voltage	13.5 VDC
Data collection (alkaline)	6 months at 10-min, ±1.5 cm/s noise
Data collection (lithium)	18 months at 10-min, ±1.5 cm/s noise

## Connectors

Bulkhead (Impulse)	LPMBH-5-FS (bronze – titanium optional)
Cable	LPML-5-MP on 5m neoprene cable

From the year 2005 Inline connectors type MCBH-8-FS will be used. This will cause the endbell to be somewhat longer than today.

## Materials

Standard model	Delrin® and polyurethane plastics with titanium screws
----------------	--

## Environmental

Operating temperature	–5°C to 45°C
Storage temperature	–15°C to 60°C
Shock and vibration	IEC 721-3-2
Pressure rating	300 m for housing Pressure sensor OK to 1.5×range

## Antifouling paint

May be applied to all surfaces

## Dimensions

Cylinder	See drawing below
Weight in air	3.5 kg
Weight in water	Neutral

## Options

Acoustic beams	Several different sensor heads available
Battery	Lithium or rechargeable Li-Ion batteries available
External battery	4 battery packs in 75 mm diameter, 500 mm length. External canister LPMBH-8-FS with PLPMIL-8-MP on 10m polyurethane cable for optional RS422 or RS232 with analog input
Connectors	

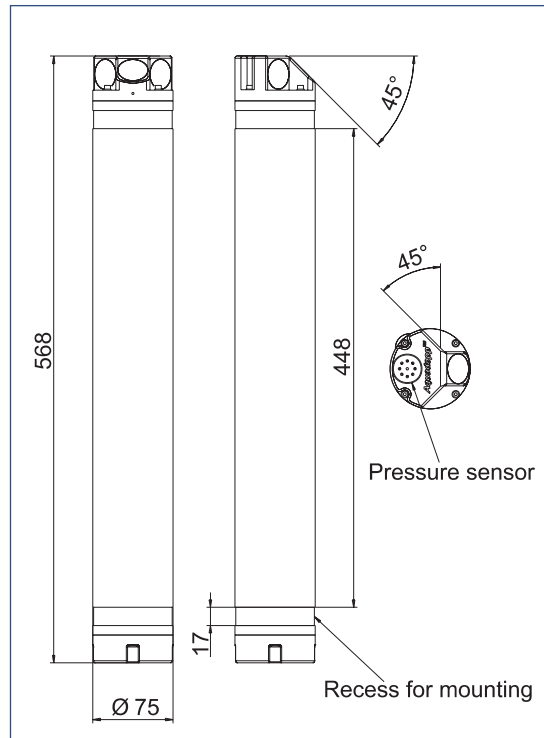

www.nortek-as.com

NORTEK AS  
Vangkroken 2  
NO-1351 Rud  
Norway

Tel: +47 6717 4500  
Fax: +47 6713 6770

E-mail: inquiry@nortek.no

青岛诺泰克测量设备有限公司

中国·青岛山东路29号顺河大厦  
电话: 086-532-5017576 5017276  
传真: 086-532-5017576  
E-mail: inquiry@nortek.com.cn  
www.nortek.com.cn

NortekUK

Mildmay House, High St.  
Hartley Wintney  
Hants. RG27 8NY

Tel: +44- 1428 751 953  
Fax: +44- 1428 751 533

E-mail: inquiry@nortekuk.co.uk

NORTEKUSA

222 Severn Avenue  
Suite 17, Building 7  
Annapolis, MD 21403

Tel: +1 (410) 295-3733  
Fax: +1 (410) 295-2918

E-mail: inquiry@nortekusa.com  
www.nortekusa.com