



KONGSBERG

# SPT and MPT 33x series

## SSBL Positioning Transponder (SPT) Multifunction Positioning Transponder (MPT)

**Deep water use - 3000 m rated**

### Introduction

The medium frequency SPT 33x and MPT 33x transponders are the subsea and seabed elements of the Kongsberg Maritime underwater positioning and navigation systems. The transponder models have 56 channels for use with the HiPAP and the HPR 400 systems.

Common for all the models are that they, on interrogation, will reply with a single- or a multi-pulse response. This reply contains different information to the HiPAP / HPR system, depending on the application.

### Applications

- Dynamic position reference for surface vessels.
- Navigation of underwater vehicles and towed bodies.
- Positioning aid for pipeline and underwater structure maintenance and construction.
- Positioning and re-entry of Blow Out Preventers (BOPs).
- Riser angle and BOP angle monitoring.
- Telemetry of inclinometers, acoustic release or external sensors.
- Sensor-reading telemetry transponder (depth and temperature).
- Position-transponder in a Long Base Line (LBL) array (MPT only).
- Master-slave transponder in an LBL array (MPT only).
- Transponder Range-Positioning mode where it positions itself (MPT only).
- Range measuring transponder (MPT only).
- Responder function.

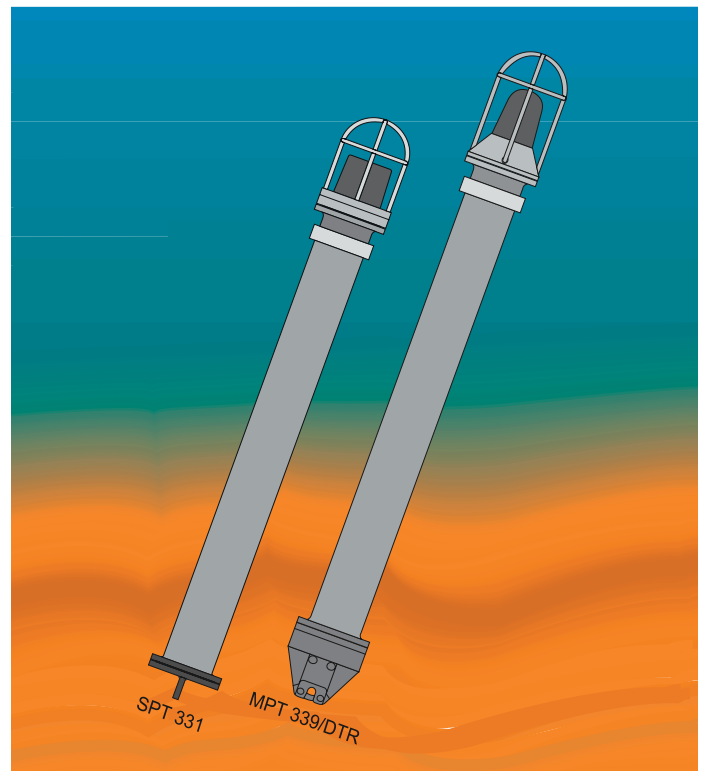

### Units and options

The transponder consists of the following main components:

- Transducer-head
- Battery
- Electronics
- Housing

The transponders are supplied with different transducer heads. The last digit in the model number identifies the  $\pm$  width of the beam pattern. The battery type provided will vary, as some types require very high energy for the transmitting pulse. The electronic

circuitry with software is modular for all models. The physical housing length varies with transponder model.

### The unique Dual Beam option

The Dual Beam option is designed for use in Long Base Line deep water positioning. The array calibration is performed with the use of a “doughnut-shaped” beam. When the calibration is completed, this beam will be switched off and the transponder will then only operate with the  $\pm 15^\circ$  beam upwards. This saves battery energy, extending the transponder’s lifetime.

### MPT

The Multifunction Positioning Transponder (MPT) can be operated in both Super-Short Base Line (SSBL) and Long Base Line (LBL) modes. All required telemetry functionality is built-in.

### SPT

The SSBL Positioning Transponder (SPT) can only operate in Super-Short Base Line. However, it has built-in telemetry capabilities and functionality. Any SPT transponder may be upgraded to an MPT.

### Compatibility

The transponders are not only compatible for use with the HiPAP / HPR 400 systems. The SPT and MPT transponders can also be used by the HPR 309 / 310 and even earlier models with the originally 14 channels. The transponder channel is preset from the manufacturer, but can be altered by either adjusting internal switches, or by acoustic telemetry from the HiPAP / HPR 400 systems. HPR 309 / 310 and earlier systems can not send telemetry for this purpose.

### Special facilities / telemetry

The acoustic telemetry link may be used to:

- Set the transponder into different modes of operation.
- Transfer data from the transponder.
- Set the transponder receiver sensitivity and transmitter power level. This is used to achieve optimal performance and battery lifetime.
- Read remaining battery lifetime.
- Change the pulse length and turnaround delay.
- Acoustic release

## Mounting and handling

The transponder may be secured to a subsea structure using mounting brackets, or fitted with an anchor weight and buoyancy collar for location on the open seabed. The unit is designed for Remotely Operated Vehicle (ROV) manipulator handling.

### Power source

The transponder is normally self-contained with power, using very long life lithium battery. A rechargeable battery with battery charger, and a Alkaline battery is available, and may be used as a replacement for the L10/36 (15/40) battery. As an option, a transponder may be externally powered.

### Housing material

Standard housing material is anodized aluminium with polyurethane coating. Units with stainless steel housing are available. For Stainless steel units, the abbreviation “St” is added to the transponder name. Both types of units are very robust.

### Naming principles

The transponder name contains three letters followed by three digits, and the letters after the digits describes the options.

<b>MPT</b>	=	Multifunction Positioning Transponder
<b>SPT</b>	=	SSBL Positioning Transponder
<b>3xx</b>	=	30 kHz band
<b>x3x</b>	=	3000 meter depth rated
<b>xx1</b>	=	$\pm 15^\circ$ beam width
<b>xx9</b>	=	$\pm 90^\circ$ beam width
<b>DuB</b>	=	Dual Beam ( $\pm 15^\circ$ upwards and horizontal 'doughnut')
<b>DT</b>	=	Build-in <u>D</u> epth and <u>T</u> emperature sensors
<b>R</b>	=	Includes Release mechanism
<b>I</b>	=	One set <u>I</u> nclinometers (X/Y angles)
<b>II</b>	=	Split unit with two sets of <u>I</u> nclinometers (X/Y angles)
<b>RspSx</b>		
<b>110Vac</b>	=	<u>R</u> esponder, <u>S</u> hort tube, mall backup battery
<b>Si</b>	=	Serial interface
<b>St</b>	=	Stainless steel (housing)

# Specifications

## Models

- SPT 331
- SPT 331/R
- SPT 331/St
- SPT 331/R-St
- SPT 331/I-St
- SPT 331/II-St
- SPT 331/RspSx110 Vac-St
- SPT 331/RspSx 110 Vac
- MPT 331/DTDuB
- MPT 331/DTRDuB
- MPT 331/DuBSi
- MPT 331/DTDuB-St
- MPT 331/DTRDuB-St
- MPT 339/DT
- MPT 339/DTR
- MPT 339/St
- MPT 339/DTR-St
- MPT 339/DTRspSx 110 Vac-St

## Basic data

Max depth rating .....3000 meters  
 Aluminium, weight in air / water ..... 35.5 kg / 13.5 kg  
 Stainless steel, weight in air / water ..... 60 kg / 42 kg  
 Overall length..... 1101-1850 mm  
 Outside diameter:  
 Aluminium, Housing / Flange..... 138 mm / 200 mm  
 Stainless steel, Housing / Flange .... 125 mm / 178 mm  
 Transducer beam widths .....±90°, ±15°  
 Source level (relative to 1 σPa. ref. 1 m):  
 - ±90°, 4 steps of 3 dB .....max 195 dB  
 - ±15°, 4 steps of 3 dB .....max 206 dB  
 - Sidebeam (DuB) .....max 190 dB  
 Rx sensitivity, 2 steps..... 100/106 dB  
 (Relative to 1 σPa)

### Frequency band:

- Rx..... 21.0 - 24.5 kHz
- Telemetry ..... 25.0 - 26.5 kHz
- Tx..... 27.0 - 31.5 kHz

## Version/R and /DTR

As in basic data, except:

Aluminium, weight in air / water ..... 38 kg / 13 kg  
 Stainless steel, weight in air / water ..... 65 kg / 46 kg  
 Overall length..... 1613 -1850 mm  
 Release:  
 - lift / buoyancy Alu / St ..... max 250 kg / 140 kg  
 Separate release battery St .....1000 releases  
 Depth, max depth on sensor..... 3000 m  
 - Resolution / Accuracy..... 0.1 m / < 0.1%  
 Temp range on sensor .....-5° to +30°C  
 - Resolution / Accuracy.....0.1°C / 0.2°C

## Version/RspSx 110 Vac

As in basic data, except:

Combined responder and transponder. Normally powered by 110 Vac. It turns into transponder mode with backup battery if 110 Vac power is lost.

Includes a 1 m pig-tail with "Gisma" U-connector.  
 Aluminium, weight in air / water ..... 25 kg / 10 kg  
 Stainless steel, weight in air / water ..... 45 kg / 33 kg  
 Overall length..... 1101-1140 mm  
 Maximum power consumption, 110 Vac .....7.5 W

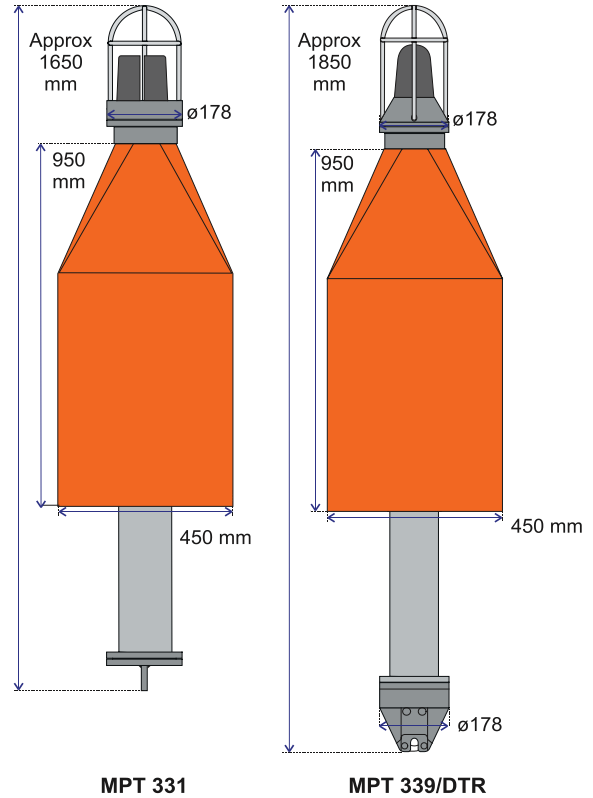

## Version/I

As in basic data, except (only St):

Maximum detectable angles:

- HPR 300 mode..... ±15°
- HPR 400 mode..... ±60°

Resolution:

- HPR 300 mode .....0.25°
- HPR 400 mode.....0.02°

Accuracy, standard sensors .....0.25°

## Version/II

As in basic and version/ I data, except (only St):

Two units, each with one set of inclinometers, and with a 9 meter interconnecting cable.

Weight in air / water:

- Transponder unit ..... 60 kg / 42 kg
- Inclinometer unit..... 20 kg / 18 kg

Outside diameter, housing / flange..125 mm / 178 mm

Overall length:

- Transponder / Inclinometer unit .1630 mm / 225 mm

## Specifications

### Version/DuB

As in basic data, except:

Aluminium weight in air / water ..... 38 kg / 14 kg  
 Stainless steel weight in air / water ..... 62 kg / 41 kg  
 Overall length ..... 1695-1731 mm  
 Transducer beamwidth Dual Beam (DuB):  
 - Vertical / Horizontal .....  $\pm 15^\circ$  /  $\pm 15^\circ$

### Version/Si

The MPT 331/DuBSi is designed to interface the Subsea Sensor Module SSM 301. The transponder and the SSM 301 are connected by a Serial line (RS-232) in a subsea cable. The SSM 301 and MPT 331/DuBSi together with HiPAP / HPR systems, provides a complete system for subsea monitoring of; Position, Orientation and Inclination. The sensor data is displayed on the APOS screen. Refer to separate product description for SSM 301.



As in basic data / DuB data, except (only Aluminium):  
 Weight in air / water ..... 39.5 kg / 16 kg  
 Overall length ..... 1810 mm

### Floating Collar

Depth rating ..... 3000 m  
 Total weight in air ..... 77 kg  
 Total buoyancy in water ..... 65 kg  
 Overall height ..... 950 mm  
 Width x depth ..... 450 x 450 mm  
 Diagonal diameter ..... 640 mm  
 Colour ..... Orange

### Batteries

### Lithium battery

#### SPT 331/MPT 331

Battery type L10/36 (15/40)  
 For more data see table.

#### SPT 331/RspSx 110 Vac

Battery type L10/40 (3/11) ..... reg.no 290-102726  
 Maximum continuous on-time ..... 30 days  
 Quiescent time ..... 155 days  
 No. of replies, low source level ..... 1.68 million  
 No. of replies, max source level ..... 0.42 million

#### MPT 339/DTRspSx 110 Vac

Same as SPT 331/RspSx 110 Vac

#### MPT 339 series

Battery type L10/50 (12/42) ..... reg. no 290-089592  
 Maximum continuous on-time ..... 120 days  
 Quiescent time ..... 620 days  
 No. of replies, low source level ..... 5.6 million  
 No. of replies, max source level ..... 1.4 million

### Alkaline battery

This battery pack may be used as a replacement for the standard L10/36 (15/40) battery.

Weight ..... 8.0 kg  
 For more data see table.

### Rechargeable battery

This battery pack may be used as a replacement for the standard L10/36 (15/40) battery.

Weight ..... 8.5 kg  
 Number of charge / discharge cycles ..... 250  
 For more data see table.

### Battery charger

Type ..... BCN 1036  
 Weight ..... 3.5 kg  
 Outline dimension ..... 172 x 120 x 231 mm

The L10/36 (15/40) battery pack may be replaced by an Alkaline or a Rechargeable battery. The specification for these batteries are shown in the table to the right.

Battery data	Lithium	Alkaline	Rechargeable
Battery Type no	L10/36 (15/40)	A10/36 (24/24)	N10/36 (18/30)
Battery Part no	290-103053	290-216804	290-212364
Maximum continuous on-time	180 days	71 days	16 days
Quiescent time	930 days	301 days	90 days
No. of replies, low source level	6.4 million	1.44 million	0.64 million
No. of replies, max source level	1.6 million	0.36 million	0.16 million

### Kongsberg Maritime AS

Strandpromenaden 50  
 P.O.Box 111  
 N-3191 Horten,  
 Norway

Telephone: +47 33 02 38 00  
 Telefax: +47 33 04 47 53  
[www.kongsberg.com](http://www.kongsberg.com)  
 E-mail: subsea@kongsberg.com



**KONGSBERG**