

---

# Datasheet

## AV-Trak Transceiver

---



---

### Description

AV-Trak is an acoustic navigation sensor designed to form part of an integrated navigation system for AUVs. The unit has been designed to meet the requirements of a variety of AUV navigation operations. The device is fully compatible with Sonardyne's family of LBL and USBL navigation equipment and systems, thus bringing a survey quality background to a new industry.

The AV-Trak sensor is a transceiver/transponder combination packaged in a light weight housing with optional 600m and 3,000m depth rated versions. (Alternatively a customised version can be provided in an electrically screened 'box' for mounting within the main AUV pressure housing). AUV installation and maintenance is simplified by the use of a separate compact transducer attached via a 1m cable. This configuration also allows a choice of, and easy interchange between, omni-directional and directional systems to suit operational requirements.

AV-Trak can provide the AUV with accurate ranging to any Sonardyne MF transponder. All Compatt frequency channels are available and any combination of four channels can be interrogated simultaneously.

Full control of the AV-Trak unit by the AUV's navigation processor is via a fully documented set of flexible commands. As well as providing simultaneous ranging to any four transponders, it also allows for individual transponders to be enabled or disabled from replying to interrogations, while still being able to respond to acoustic commands. This is an important feature for preserving transponder battery life and avoiding interference from other transponders.

Control is via a serial RS232 interface, which includes a function to switch into transponder mode for tracking via a surface vessel mounted USBL.

An internal 'watchdog' option is also available that monitors serial line activity and has the ability to switch the unit to transponder mode for emergency relocation should the AUV's main navigation system fail.

---

### Key Features

- Navigation in full or sparse arrays using standard LBL techniques
  - AUV position correction and calibration in deep water via LBL or surface USBL methods
  - Tracking during deployment and recovery operations
  - Acoustic aiding of the AUV's on-board navigation system
  - Seabed transponder position fixing
  - Independent verification of IMU and DVL based navigation systems
  - AUV to AUV ranging
  - Emergency relocation
-

# Specifications

## AV-Trak Transceiver

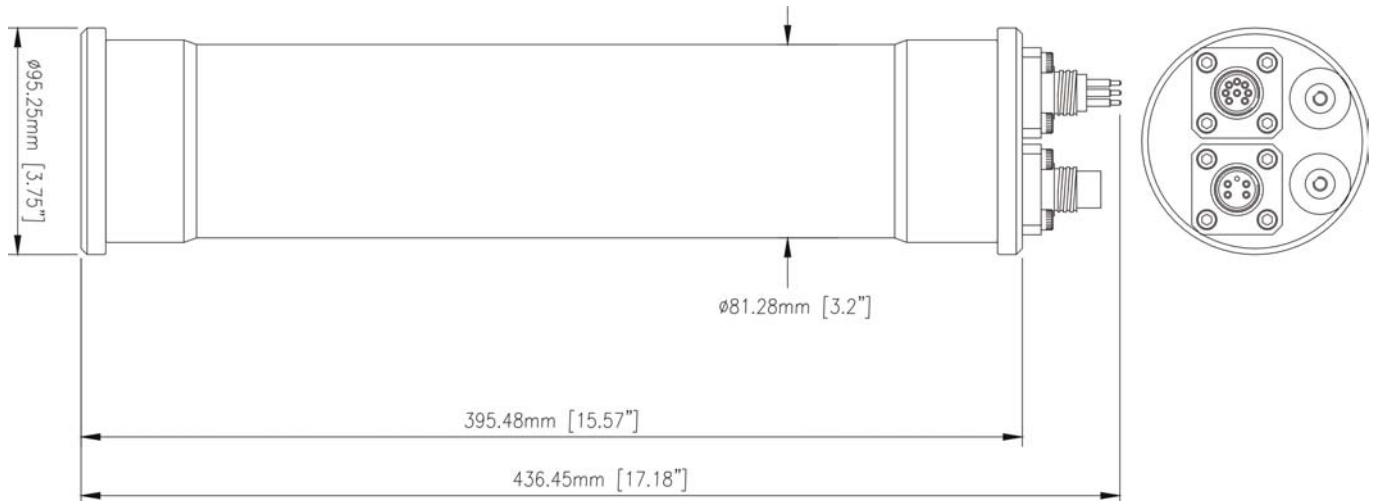

Feature		Type 7995-000-04	Type 7995-000-02
Depth Rating		600 Metres	3,000 Metres
Operating Frequency		MF (19kHz–36kHz)	MF (19kHz–36kHz)
Remote Transducer		Omni-Directional or Directional	Directional
Transmit Source Level (re 1µPa @1 m)	Omni-Directional	190dB	N/A
	Directional Transducer	198dB	198dB
Pulse Length		4ms	4ms
Receiver Sensitivity (re 1µPa)		<100dB	<100dB
Acoustic Doppler Tolerance		+/-18 knots	+/-18 knots
Power Supply		External 10 to 72 V DC	External 10 to 72 V DC
Power Consumption		1.2 watts	1.2 watts
Power & Comms Cable Connector		8 pin Subconn type MCL8F	8 pin Subconn type MCL8F
Mechanical Construction		Aluminium Alloy hard Anodised	Aluminium Alloy hard Anodised
Dimensions (LxDia)	Electronic Housing	437mm (17.2") x 95mm (3.7")	437mm (17.2") x 95mm (3.7")
	Remote Transducer	229mm (9.01") x 69mm (2.7")	229mm (9.01") x 69mm (2.7")
	Remote Transducer Cable	1 Metre	1 Metre
Weight in Air	Electronic Housing	2.45Kg	4.21Kg
	Remote Transducer	1.13Kg	1.23Kg
Weight in Water	Electronic Housing	0.32Kg	1.41Kg
	Remote Transducer	0.57Kg	0.57Kg