

SKIPPER DL 850 DUAL AXIS DOPPLER SPEED LOG



SKIPPER DL 850 speed log system is the latest in computerbased speedlog technology for use onboard merchant- and larger fishing vessels.

DL 850 is a dual axis speed log, working on the doppler principle. It provides information about transversal and longitudinal ship speed plus possible drift speed and angle.

DL 850 gives information on both speed over ground and through water.

DL 850 has a backlit, colour LCD display with «Soft-Keys» to choose between different screens. The operator can choose between several screens and through this obtain all necessary information concerning speed and drift.

DL 850 has a built-in echo sounder function for depths down to 100m, with the possibility to measure current in three depth layers down to 50m, and reading of sea temperature.

The system can be extended to include a dual axis electromagnetic sensor.

The system may be interfaced with most modern peripheral equipment.

Operation and Settings

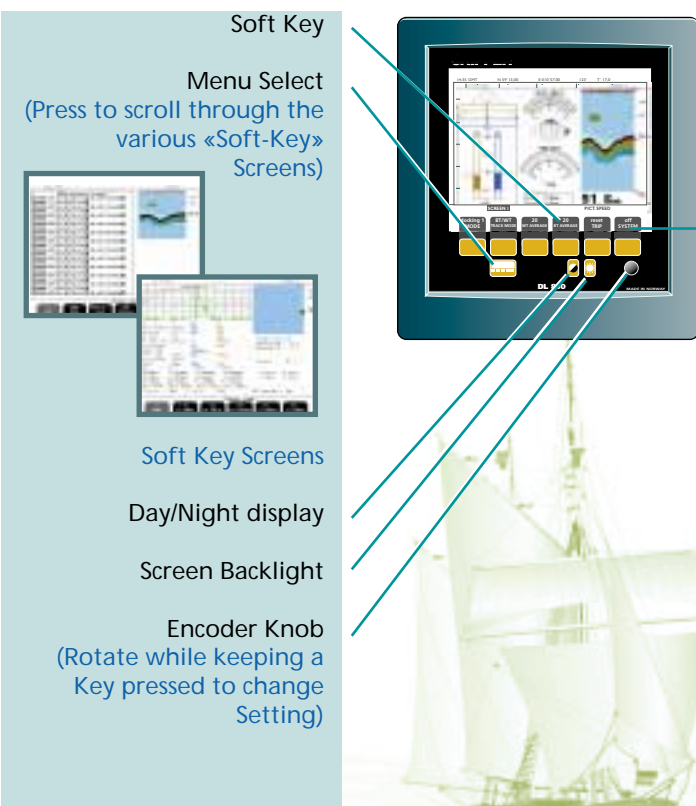

Soft Key Screens

1	docking1 MODE	BT/WT TRACK MODE	20 WT AVERAGE	20 BT AVERAGE	reset TRIP	off SYSTEM
2	25% ES POWER	100m DEPTH	1470m/s SOUND	72% ES GAIN	42% ES TUG	off SYSTEM
3	94.11 YR.MONTH	13 DAY	15 HOURS	03 MINUTES	on SIMULATE	kts VESSELSPD
4	english LANGUAGE		meters ES RANGE	nm DISTANCE		
5			result WT OUT MODE		m/sec SOUNDSPD	
6	ch 1 OUT NUM	200/nm PULSES NUM	result WT OUT MODE	-19.3kts ANA MIN		
7	ch 1 OUT NUM	0-10V OUT MODE			19.4kts ANA MAX	
8	1 COM	4800 BAUD	none 8,1 DATA	DPT MESSAGE	on OUTPUT	output DISPLAY
9	100ms CYCLE DEL		100% SL POWER	on ES MODE	on SL WT MODE	on SL BT MODE
10	300mcs ES PING		42% ES TUG	72% ES GAIN	217 ES MAX G	
11	2ms WT PING	0,2ms WT DELAY	2ms WT CYCLE	220 WT MIN G	1 WT AGC	30 WT THRESH
12	< 10m BT RANGE	100mcs BT TVG	800mcs BT TVG	140 BT MIN G	240 BT MAX G	250 BT THRESH

Actual info in soft-key screens may vary from illustration

SKIPPER DL 850 System overview

Typical installation

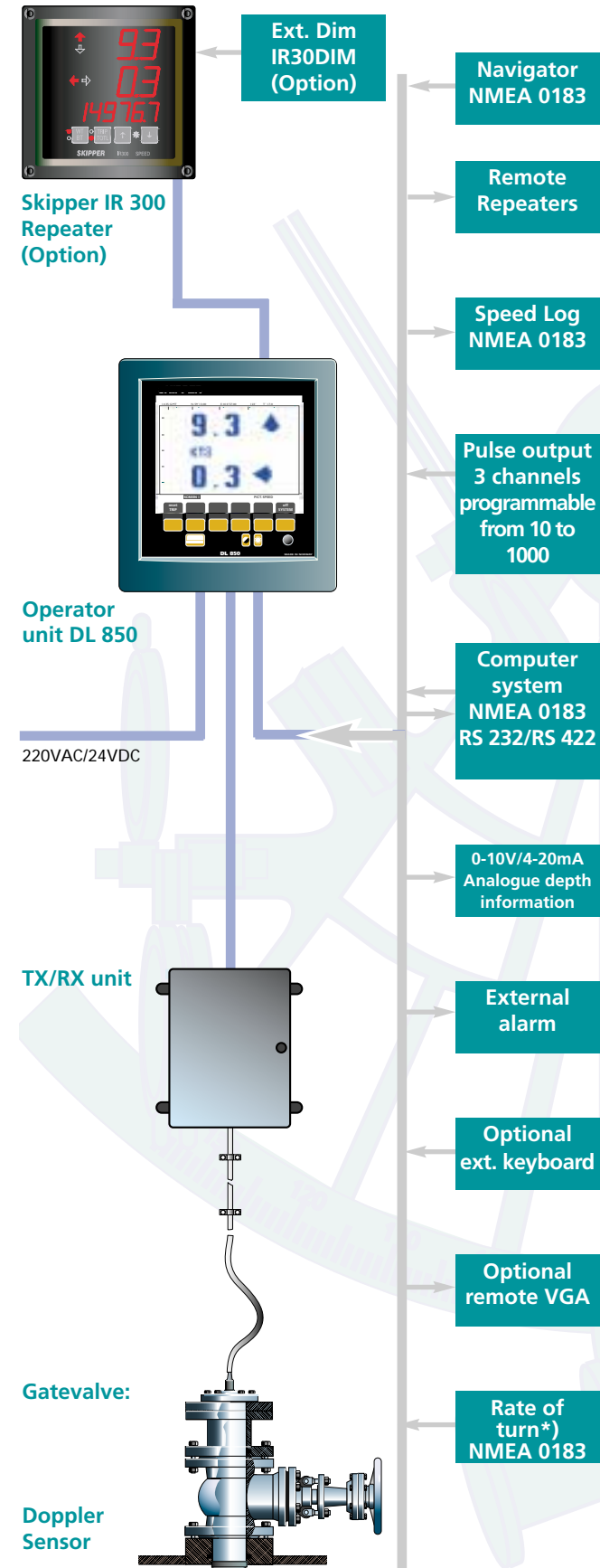

Interface, In- and Outputs:

Specifications:

- Power Supply** - AC: 220V/110V 50/60Hz. DC: 20-40V
- Power Consumption** - Max. 100W
- Display** - 150x200mm (104 inch) Colour LCD screen with adjustable backlight.
- Memory** - For retaining operational settings.
- Log:**
 - Speed Range** - 0-40 kts in both axis
 - Bottom Lock** - 1-75 m
 - Water Track** - Less than 3 m. below sensor
 - Frequency** - 540 kHz/Beam width 4 x 5,5'
 - Output Power** - 50 W/Element adjustable
 - Current Indicator** - 3 layers between 3 - 50 m. *)
 - Accuracy** - 0,2% of speed
- Echo sounder**
 - Range** - Max. 100 m.
 - Frequency** - 270 kHz/Beamwidth 8'
 - Output Power** - 100 W adjustable
 - Measuring accuracy** - Better than 1%
 - Depth alarms** - Deep and Shallow Limits
- Calendar/Clock** - Year-month-day / Hours-min.-sec. - 24 hours system.
- Outputs** - Analogue 0 - 10V and 4 - 20 mA - NMEA 0183 / RS 232 / RS 422*. - VGA, Analogue digital remote display. - Interface for external printer*).
- Inputs** - From sensor (Speed, depth and temp.) - NMEA 0183 / RS 232 / RS 422. - Rate of turn *) - Built-in test simulator.
- Option Languages** *) - English, French, German, Spanish, Russian, Norwegian.
- Classification Service** - IMO - Available in all major harbours, world-wide through extensive dealer network.

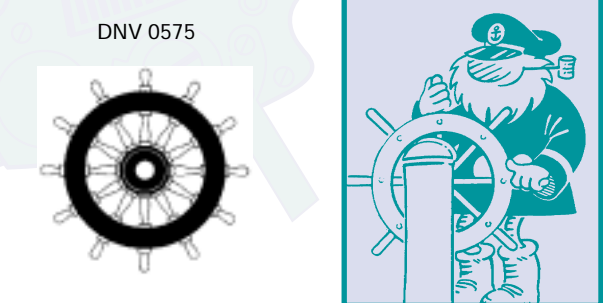

Specifications may change without prior notice

Dimensions:

All measurements in millimeters



Transceiver

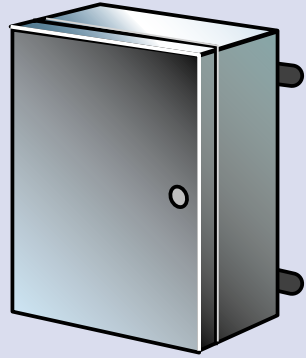

Dimensions:
 H: 450 mm
 W: 300 mm
 D: 260 mm
 Weight: 16 kg

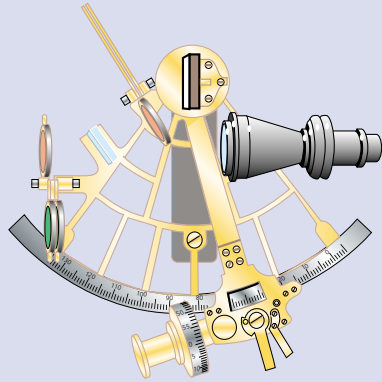

Doppler Log Sensor

Stainless steel,
 TP 316/TP 316L
 Weight: 12,5 kg

Standard 30m cable
 (weight 9 kg)

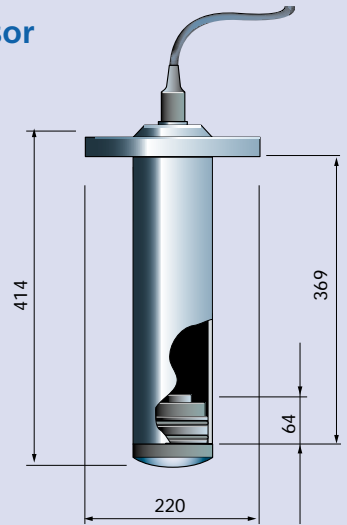

Gatevalve

Stainless steel,
 TP 316/TP 316L

Weight: 63 kg

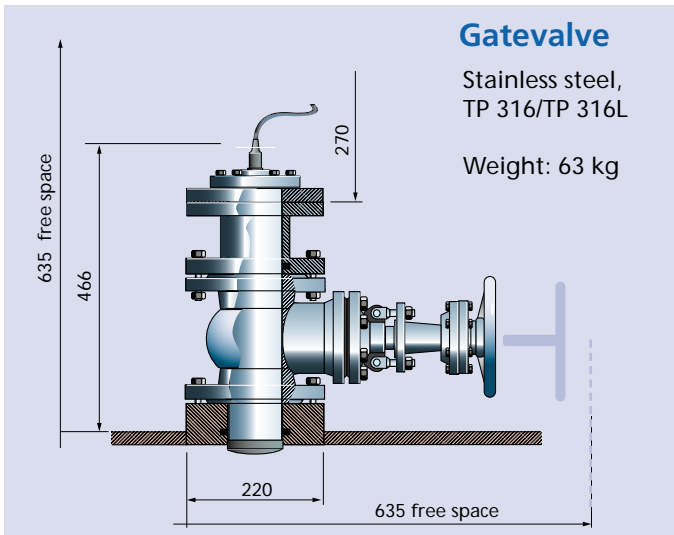

Operator unit

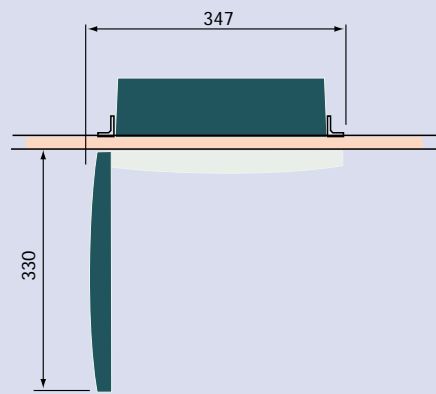
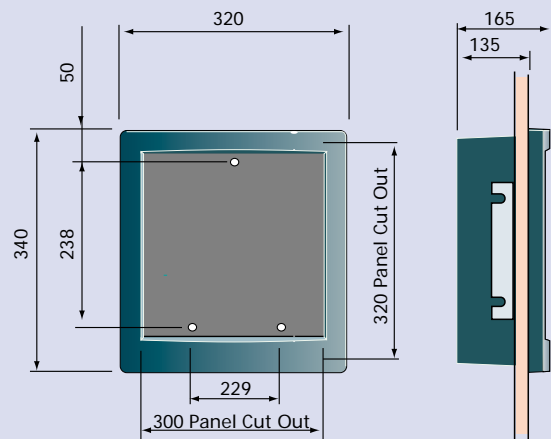

Weight: 10 kg

SKIPPER DL 850 DUAL AXIS DOPPLER SPEED LOG



"SERVE YOU FURTHER"



www.skipper.no

SKIPPER ELECTRONICS build navigation equipment for the merchant as well as the fishing fleet, based on experience, research and tradition. Our products are known worldwide for reliability, sophistication and good value for money.

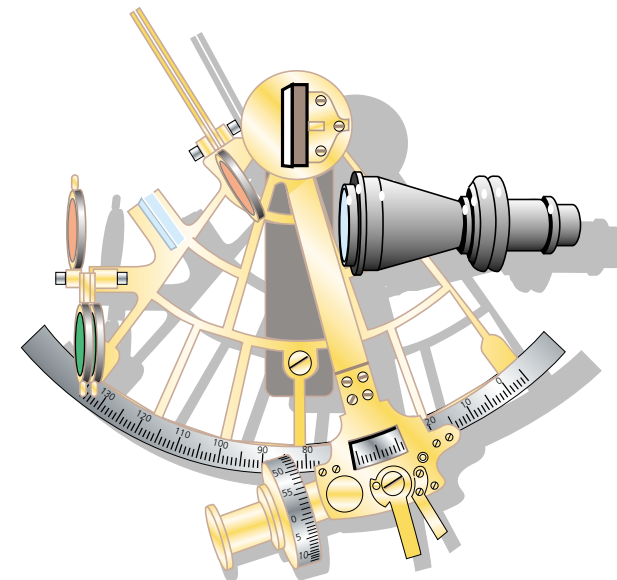

Distributor/Agent

SKIPPER

SKIPPER ELECTRONICS AS

Ryensvingen 5, P.O.Box 151, Manglerud
 0612 OSLO, NORWAY
 Phone +47 23 30 22 70 - Fax +47 23 30 22 71
 e-mail: skipper@skipper.no - Web: www.skipper.no

SKIPPER

SKIPPER ELECTRONICS AS

DESIGN OG ILLUSTRASJONER: N. E. HEGGER - TRYKK: feb-00